

Sens' Temperature Outdoor

Temperature Modbus Slave

Reference AC1101-02



Application

Sensor for outdoor temperature measurement: solar production plants and buildings. Stainless Steel external probe for faster response.

Types Available

Outdoor sensor and temperature - active RS485 Modbus

Security Advice-Caution



The installation and assembly of electrical equipment should only be performed by authorized personnel. The product should only be used for the intended application. Unauthorised modifications are prohibited! The product must not be used in relation with any equipment that in case of a failure may threaten, directly or indirectly, human health or life or result in danger to human beings, animals or assets. Ensure all power is disconnected before installing. Do not connect to live/operating equipment.

Please comply with

- Local laws, health & safety regulations, technical standards and regulations
- Condition of the device at the time of installation, to ensure safe installation
- This data sheet and installation manual
-

Notes on Disposal



As a component of a large-scale fixed installation, those products are intended to be used permanently as part of a building or a structure at a pre-defined and dedicated location, hence the Waste Electrical and Electronic Act (WEEE) is not applicable.

However, most of the products may contain valuable materials that should be recycled and not disposed of as domestic waste. Please note the relevant regulations for local disposal.

Build-up of self-heating by electrical dissipative power

Temperature sensors with electronic components always have a dissipative power, which affects the temperature measurement of the ambient air. The dissipation in active temperature sensors shows a linear increase with rising operating voltage. This dissipative power has to be considered when measuring temperature.

In case of a fixed operating voltage ($\pm 0,2$ V) this is normally done by adding or reducing a constant offset value.

Transducers work with a variable operating voltage, only one operating voltage can be taken into consideration, for reasons of production engineering. Transducers 0..10 V / 4..20 mA have a standard setting at an operating voltage of 24 V =.

That means, that at this voltage, the expected measuring error of the output signal will be the least.

For other operating voltages, the offset error will be increased by a changing power loss of the sensor electronics.

Remark: Occurring draft leads to a better carrying-off of dissipative power at the sensor. Thus temporally limited

fluctuations might occur upon temperature measurement.

Technical Characteristics

Description	Outdoor Temperature Sensor Modbus Slave
Network technology	RS485 Modbus, RTU, half-duplex, baud rate 9.600, 19.200, 38.400 or 57600, parity: none (2 stopbits), even or odd (1 stopbit)
Power supply	15..35V
Output signal range temperature	-20 to +80°C
Operating temperature	-35 to +70°C
Accuracy temperature	$\pm 0,5^\circ\text{C}$ (typ. at 21 °C)
Protection	IP65 according to EN 60529
Cable entry	M25, for wire max. $\varnothing=7$ mm, seal insert for fourfold cable entry
Electrical connection	Mainboard: removable plug-in terminal, max. 2,5 mm ² Terminal: removable plug-in terminal, max. 1,5 mm ²
Ambient condition	max. 85% rH

Mounting Advices

In case of outdoor installation avoid direct rain and sun contact. Probably use sun respectively rain protection. Cable entry from bottom or side. For side cable routing set loop so that precipitation can drain defined. Observe permissible ambient condition.

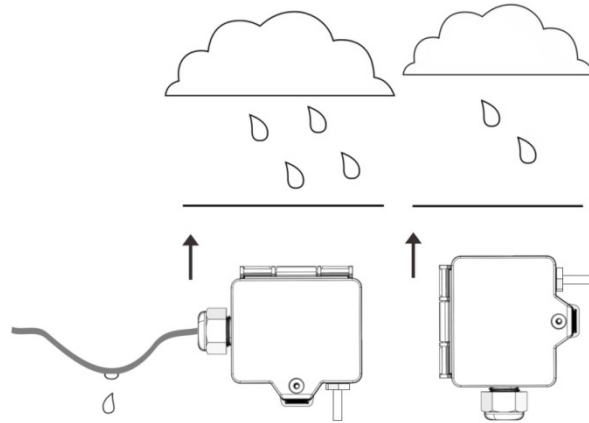

Connection Plan

If the RS485 cable is looped through, connect both cable shields using the enclosed 2-pol. Connect terminal as shown.

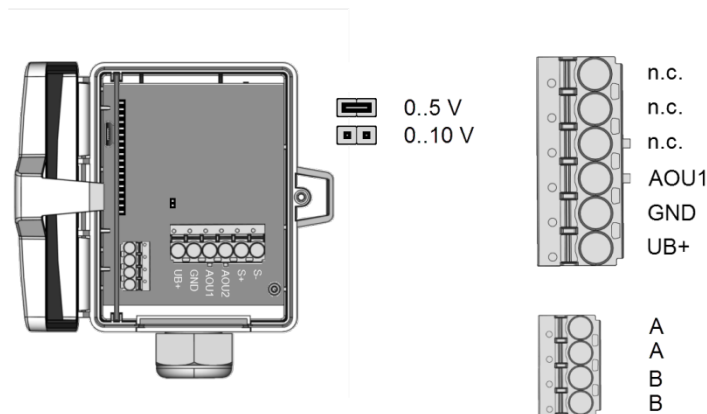

Register address 400 = 1 (unit SI)

Address	Access	Description	Resolution/Unit
0	R	Temperature	SI 0.1 °C

Register address 400 = 2 (unit SI)

Address	Access	Description	Resolution/Unit
0	R	Temperature	Imperial 0.1 °F

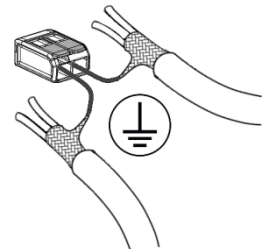

The equipment may vary from the description in this document. Webdyn reserves the right to make changes to the product(s) and or information contained herein without notice. This document may not be considered as a contract specification.

If the RS485 cable is looped through, connect both cable shields using the enclosed 2-pol. Connect terminal as shown.

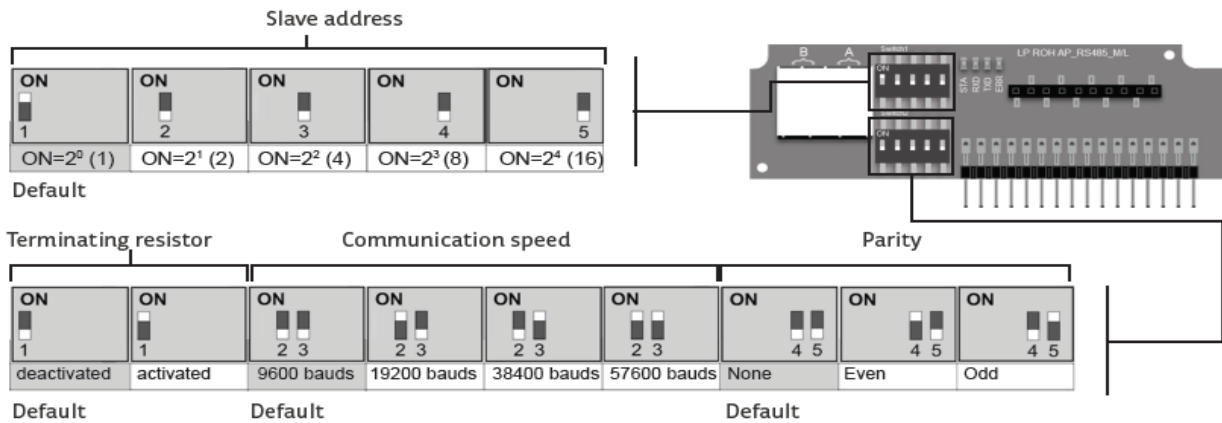

Connection Plan

